

Specifications

*Appendix to
SNAP12 Multi-Source Agreement*

**Revision 1.1
May 15, 2002**

Table of Contents, Tables and Figures

Mechanical Interface.....	3
1. Package Dimensions	3
2. Electrical and Optical Connectors.....	4
3. Host Board Layout	5
4. Host Faceplate Layout for Panel Accessed Modules	6
Electrical Interface	7
5. Power Supply Specifications	7
6. Data Signal Specifications	7
7. Control and Status Signal Specifications.....	9
8. Electrical Pin Assignments	9
9. Control and Status Timing Diagrams.....	15
Optical Interface.....	18
10. Transmitter Optical Specifications.....	18
11. Receiver Optical Specifications.....	18
12. Optical Signal Locations.....	19
13. Cable Plant Specifications	19
Electrical Interface – Application Examples.....	20
14. Application Examples	20

List of Tables

Table 1 - Module Dimensions	3
Table 2 - Host Board Dimensions.....	5
Table 3 - Faceplate Dimensions	6
Table 4 - Power Supply Parameters.....	7
Table 5 – AC-coupling parameters.....	8
Table 6 – DC-coupling parameters.....	8
Table 7 - Control and Status Signal Level Specifications.....	9
Table 8 - Transmitter Module Pin Functionality	9
Table 9 - Receiver Module Pin Functionality	12
Table 10 - Timing Requirements of Control and Status Signals	17
Table 11 - Transmitter Optical Specifications.....	18
Table 12 - Receiver Optical Specifications.....	18
Table 13 - Transmitter Optical Signal Locations.....	19
Table 14 - Receiver Optical Signal Locations.....	19
Table 15 - Cable Plant Specifications.....	19

List of Figures

Figure 1 - Isometric Drawings.....	3
Figure 2 - Module Dimensions	4
Figure 3 - Host Board Mechanical Layout	5
Figure 4 - Host Faceplate Layout	6
Figure 5 - Typical Power Supply Filtering Scheme	7
Figure 6 - Differential Data Signal Levels (AC-Coupling).....	8
Figure 7 - Transmitter Pin Layout	14
Figure 8 - Receiver Pin Layout	15
Figure 9 - Transmitter Fault	15
Figure 10 - Transmitter Initialization and Fault Reset Timing.....	16
Figure 11 - Transmitter Enable / Disable Timing	16
Figure 12 - Receiver Signal Detect Timing.....	16
Figure 13 - Receiver Enable Timing	17
Figure 14 - AC-Coupling into Tx Optical Module.....	20
Figure 15 - DC-Coupling into Tx Optical Module.....	20
Figure 16 - AC-Coupling from Rx Optical Module	21
Figure 17 - DC-Coupling from Rx Optical Module.....	21

Mechanical Interface

1. Package Dimensions

A common mechanical outline is used for pluggable parallel optical transmitter and receiver modules. The only difference between the modules is the position of the electrical receptacle relative to the mounting feet. Package dimensions and tolerances are itemized in Table 1.

Figure 1 - Isometric Drawings

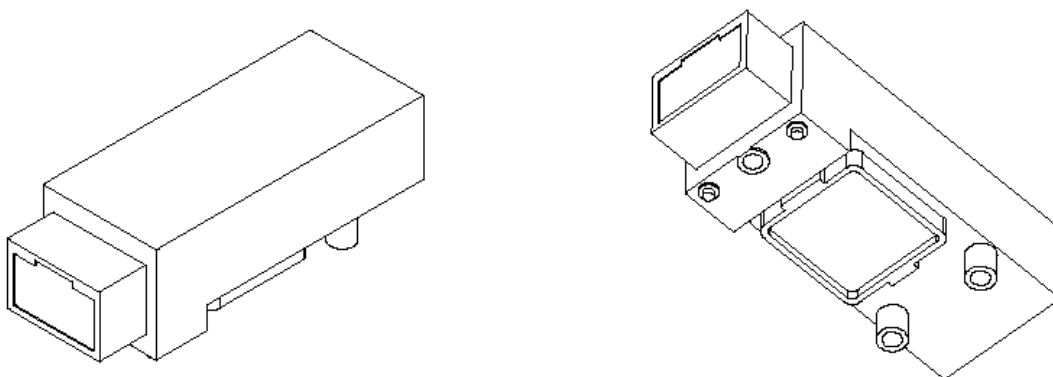

Table 1 - Module Dimensions

Key	Value mm	Tolerance mm	Comments
A1	42.67	MAX	Length of module body, less optical receptacle assembly
B1	18.00	MAX	Width of module body
C1	15.25	MAX	Width of optical receptacle assembly
D1	2.70	MIN	Height of bottom of optical receptacle assembly
E1	15.70	MAX	Height of top of optical receptacle assembly
F1	7.40	MIN	Length of optical receptacle assembly
	10.00	MAX	
G1	15.55	MAX	Height of top of module
H1	3.00	MIN	Clearance over host board at rear of module
J1	0.31	MIN	Height of standoff boss on front posts
K1	0.76	±0.12	Height of front posts
L1	31.75	±0.50	Distance from rear post to front plane, less optical receptacle assembly
M1	30.23	BASIC	Distance from front to rear posts
N1	13.72	BASIC	Distance between posts, side-to-side
P1	1.14	BASIC	BGA pin A1 location
R1	19.43	BASIC	BGA pin A1 location, Transmitter
S1	Ø3.63	±0.25	Rear posts' diameter
T1	THREAD	—	2-56 UNC-2B threads, minimum of 3.50 mm deep
U1	16.89	BASIC	BGA pin A1 location, Transmitter
V1	Ø1.30	±0.12	Front posts' diameter
W1	Ø2.50	±0.35	Diameter of standoff boss on front posts
X1	—	—	Position of optical plane
Y1	—	—	Position of optical plane

Dimensions with reference designators ending in "2" (e.g., C2) are defined in Table 2.

SNAP12 MSA

Figure 2 - Module Dimensions

Tolerancing per ASME Y14.5M-1994.
All dimensions are in millimeters.

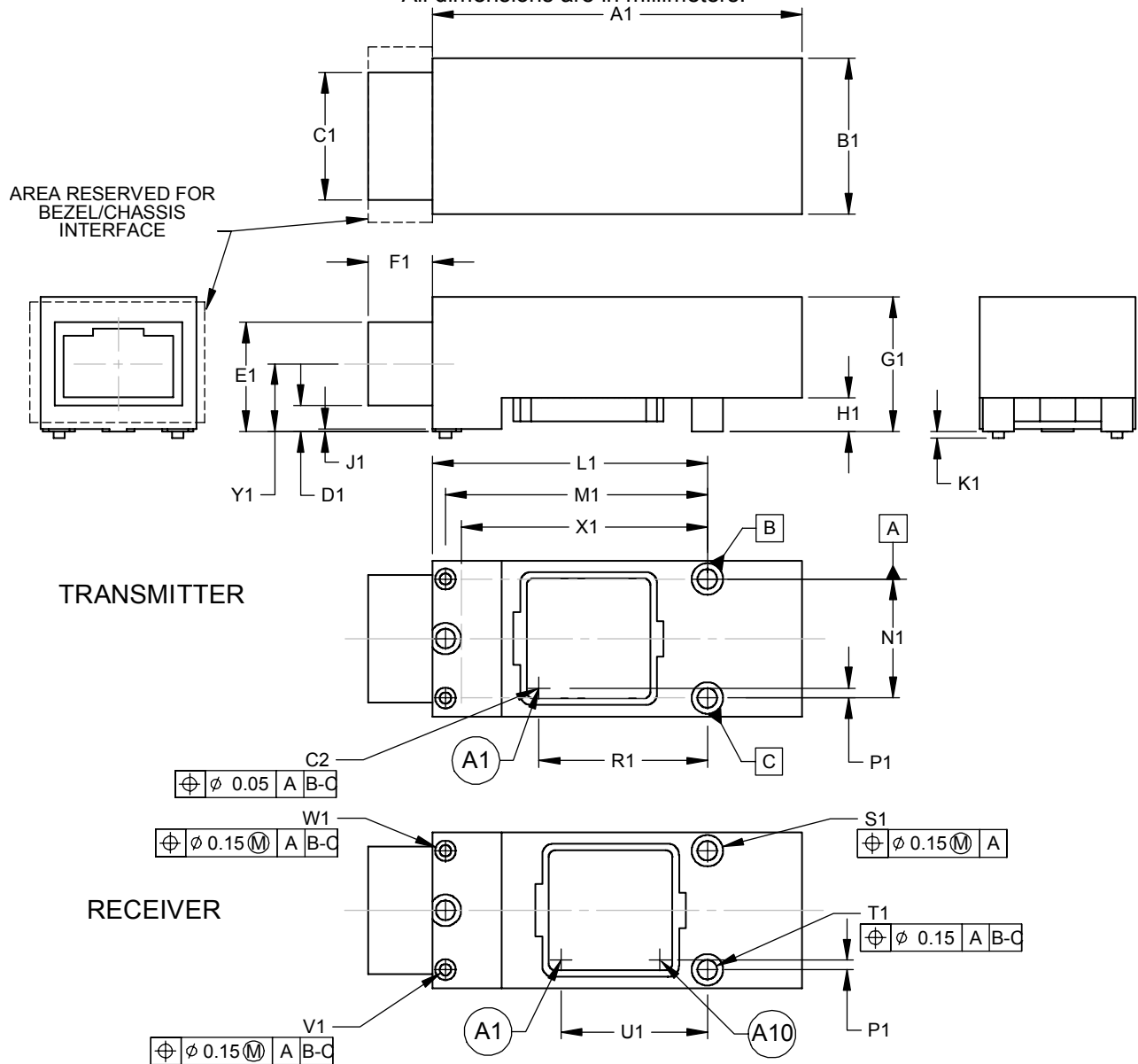

2. Electrical and Optical Connectors

The objective of this section is to specify the electrical and optical connector interface to sufficiently insure performance, intermateability and maximum supplier flexibility.

The pluggable parallel optical modules shall use a 100 position FCI Meg Array receptacle (FCI PN: 84513-101) or equivalent electrical connector. As shown in Figure 2 – Module Dimensions, the electrical connectors are keyed to ensure proper insertion.

The pluggable parallel optical modules shall accept a MPO optical connector that conforms to IEC 61754-7. As shown in Figure 2 – Module Dimensions, the optical connectors are keyed to ensure proper insertion.

3. Host Board Layout

A typical host board mechanical layout for attaching the pluggable parallel optical transmitter and receiver modules is shown in Figure 3. The host electrical connector must be a 100-position FCI Meg Array plug (FCI PN: 84512-101) or equivalent.

Host enclosures that use pluggable parallel optical modules should provide appropriate clearances between modules to allow insertion and extraction of the optical connector without the use of special tools. A recommended minimum separation distance between modules is dimension A3 of Table 3.

Figure 3 - Host Board Mechanical Layout

Tolerancing per ASME Y14.5M-1994.
All dimensions are in millimeters.

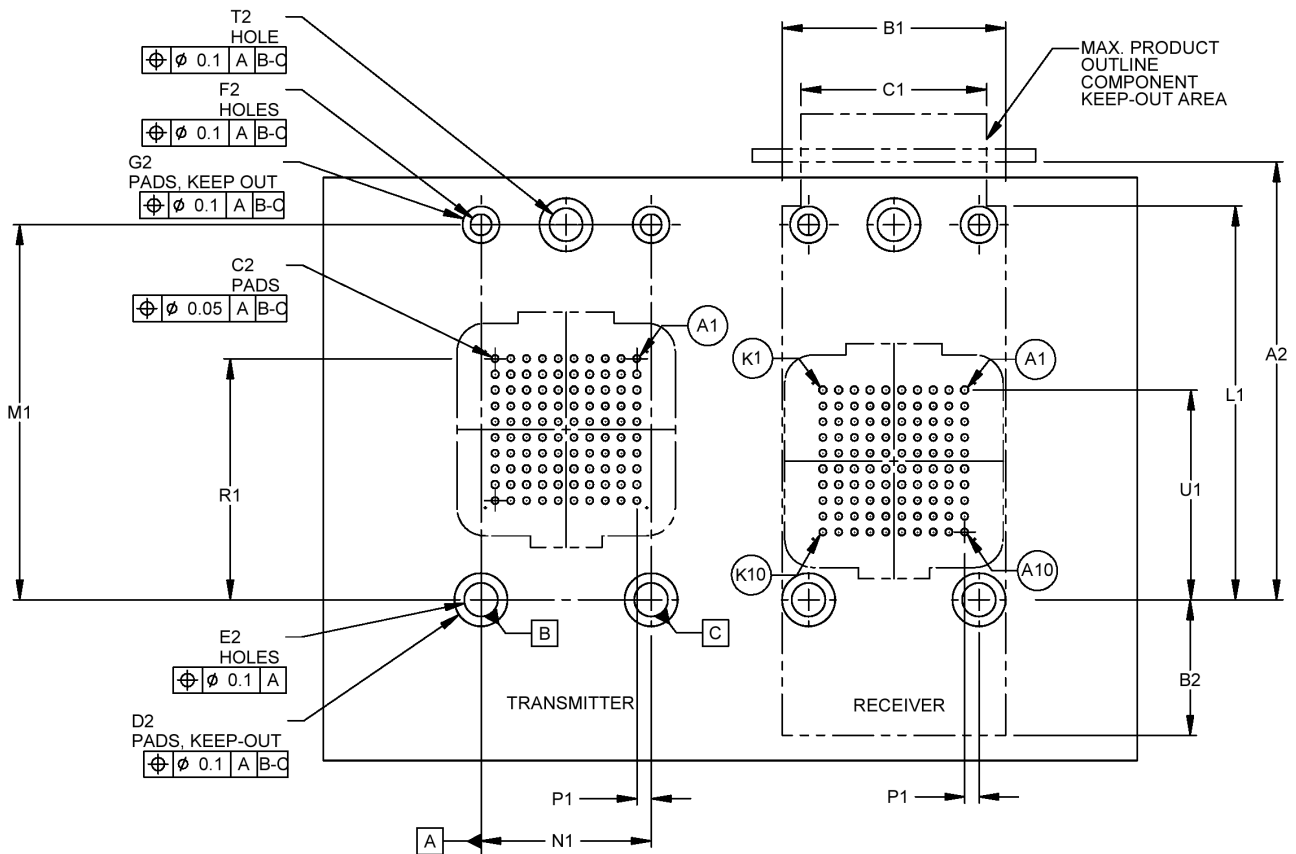

Table 2 - Host Board Dimensions

Key	Value mm	Tolerance mm	Comments
A2	35.31	±0.75	Distance from rear post to inside surface of bezel
B2	10.92	MAX	Distance from rear post to rear of module keep-out area
C2	∅0.58	±0.05	Diameter of pad in BGA pattern
D2	∅4.30	MIN	Diameter of keep-out pad for rear post
E2	∅2.69	±0.12	Diameter of hole for mounting screws: two rear and one front
F2	∅1.70	±0.12	Diameter of hole for front post
G2	∅3.00	±MIN	Diameter of keep-out pad for front post

Dimensions with reference designators ending in "1" (e.g., B1, C1) are defined in Table 1.

4. Host Faceplate Layout for Panel Accessed Modules

A typical host faceplate mechanical layout for the pluggable parallel optical modules is shown in Figure 4. The host faceplate should be clear of nearby moldings and covers that might block access to the optical connector.

Figure 4 - Host Faceplate Layout

Tolerancing per ASME Y14.5M-1994

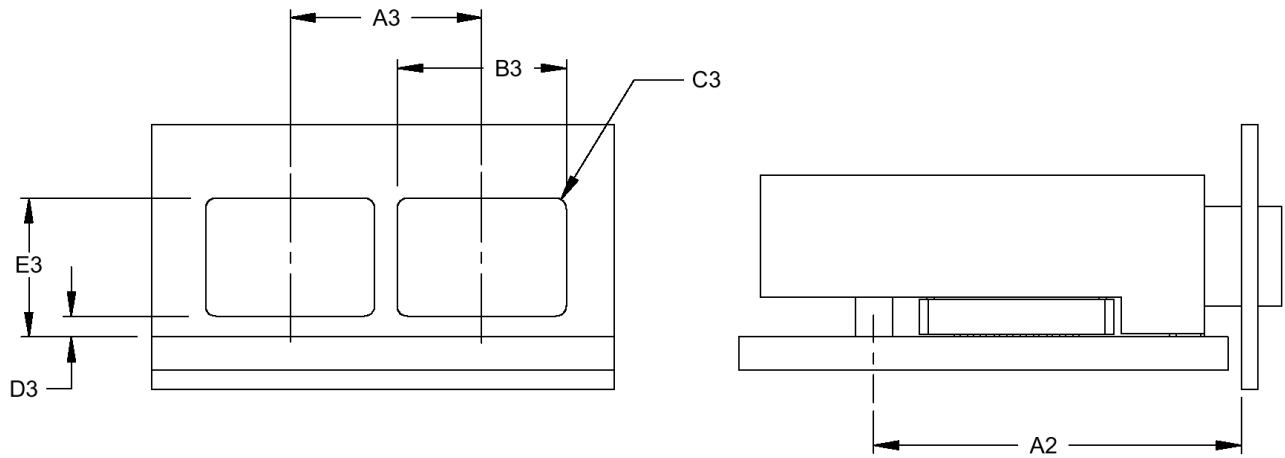

Table 3 - Faceplate Dimensions

Key	Value mm	Tolerance mm	Comments
A3	18.42	MIN	Center-to-center spacing for adjacent modules
B3	16.21	±0.25	Width of opening in faceplate
C3	1.00	MAX	Corner radius of opening in faceplate
D3	2.00	±0.20	Height from host PCB to bottom of faceplate opening
E3	16.00	±0.20	Height from host PCB to top of faceplate opening

Dimensions with reference designators ending in "2" (e.g., A2) are defined in Table 2.

Electrical Interface

5. Power Supply Specifications

The pluggable parallel optical modules use a single power supply. Specifications for supply voltage, current draw and power consumption are listed in the following table. A filtered power supply is highly recommended. A typical filtering scheme is shown in the following figure. The chassis and electrical grounds are DC-isolated on the modules. It is recommended to tie the module case to chassis ground through the three mounting screws. These are called out in E2 of Table 2.

Table 4 - Power Supply Parameters

Parameter	Min	Max	Units
Supply voltage (VCC)	3.135	3.465	V
Supply voltage – absolute max for which no damage will occur		4.5	V
Supply current – receiver		450	mA
Power consumption – receiver		1.5	W
Supply current – transmitter		500	mA
Power consumption – transmitter		1.75	W

For case temperatures from 0 to 80°C.

Figure 5 - Typical Power Supply Filtering Scheme

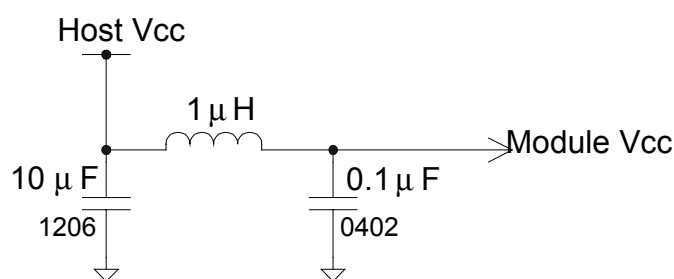

L1 - 1 µH or Murata BLM21P221SG

6. Data Signal Specifications

The pluggable parallel optical modules make use of differential current mode logic (CML) for the high-speed data inputs and outputs. AC coupling is recommended; however the modules may be DC-coupled if appropriate voltage levels are maintained. A blocking capacitor of 100 nF is recommended for typical applications. However different applications may require a larger or smaller value. Application examples are included at the end of this specification.

Table 5 – AC-coupling parameters

Parameter	Min	Max	Units
Input voltage – differential (single-ended)	200 (100)	800 (400)	mV
Input voltage – absolute max for which no damage will occur		1400	mV
Input termination resistance – differential (single-ended)	80 (40)	120 (60)	Ω
Output voltage – differential (single-ended)	450 (225)	800 (400)	mV
Output termination resistance – differential (single-ended)	80 (40)	120 (60)	Ω
Pull-up voltage – VPP	VCC		V

Figure 6 - Differential Data Signal Levels (AC-Coupling)

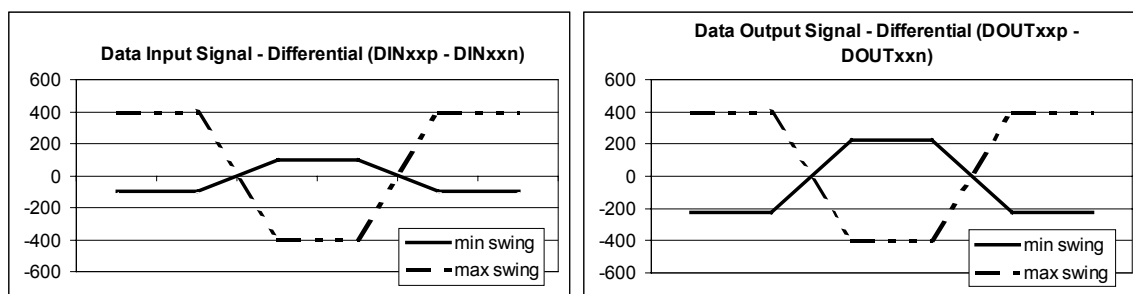

If optional DC-coupling is used to connect with the host circuitry then the following parameters must be maintained.

Table 6 – DC-coupling parameters

Parameter	Min	Max	Units
Input voltage – absolute	1.5	VCC	V
Input voltage – differential (single-ended)	Values per Table 5 – AC-coupling parameters		
Input voltage – absolute max for which no damage will occur			
Input termination resistance – differential (single-ended)			
Output voltage – temporal average, common mode	VPP - 0.7	VPP - 0.2	V
Output voltage – instantaneous absolute	VPP - 1.1	VPP + 0.1	V
Output voltage modulation – differential (single-ended)	400 (200)	900 (450)	mV
Output termination resistance – differential (single-ended)	Values per Table 5 – AC-coupling parameters		
Pull-up voltage – VPP	1.8 \pm 5%, 2.5 \pm 5%, or VCC		V

7. Control and Status Signal Specifications

The pluggable parallel optical modules make use of LVTTTL/LVCMOS for the control and status inputs and outputs. These signal levels are compatible with JEDEC JESD8-B specifications.

Table 7 - Control and Status Signal Level Specifications

Parameter	Min	Max	Units
Input voltage – logic LOW	GND	800	mV
Input voltage – logic HIGH	2000	VCC	mV
Input current		±5	µA
Output voltage – logic LOW	GND	400	mV
Output voltage – logic HIGH	2400	VCC	mV
Output current		± 2	mA

8. Electrical Pin Assignments

Pin functionality for the pluggable parallel optical transmitter and receiver modules are itemized in Tables 5 and 6 respectively. Mechanical layouts for the transmitter and receiver modules are shown in Figures 7 and 8 respectively.

Table 8 - Transmitter Module Pin Functionality

TX Pin	Name	Type	Function
A1	NIC		no internal connection within module
A2	GND	P	electrical ground
A3	GND	P	electrical ground
A4	NIC		no internal connection within module
A5	GND	P	electrical ground
A6	GND	P	electrical ground
A7	NIC		no internal connection within module
A8	NIC		no internal connection within module
A9	NIC		no internal connection within module
A10	Vendor Specific		Vendor specific; leave unconnected when not in use; not required for MSA compatibility
B1	GND	P	electrical ground
B2	DIN9p	I	Module input channel 9+
B3	DIN9n	I	Module input channel 9-
B4	GND	P	electrical ground
B5	DIN10n	I	Module input channel 10-
B6	DIN10p	I	Module input channel 10+
B7	GND	P	electrical ground
B8	GND	P	electrical ground
B9	GND	P	electrical ground
B10	Vendor Specific		Vendor specific; leave unconnected when not in use; not required for MSA compatibility
C1	GND	P	electrical ground
C2	GND	P	electrical ground
C3	DIN8p	I	Module input channel 8+

SNAP12 MSA

TX Pin	Name	Type	Function
C4	DIN8n	I	Module input channel 8-
C5	GND	P	electrical ground
C6	DIN11n	I	Module input channel 11-
C7	DIN11p	I	Module input channel 11+
C8	GND	P	electrical ground
C9	GND	P	electrical ground
C10	Vendor Specific		Vendor specific; leave unconnected when not in use; not required for MSA compatibility
D1	GND	P	electrical ground
D2	GND	P	electrical ground
D3	GND	P	electrical ground
D4	DIN7p	I	Module input channel 7+
D5	DIN7n	I	Module input channel 7-
D6	GND	P	electrical ground
D7	DIN12n	I	Module input channel 12-
D8	DIN12p	I	Module input channel 12+
D9	GND	P	electrical ground
D10	Vendor Specific		Vendor specific; leave unconnected when not in use; not required for MSA compatibility
E1	GND	P	electrical ground
E2	DIN6p	I	Module input channel 6+
E3	DIN6n	I	Module input channel 6-
E4	GND	P	electrical ground
E5	DIN3p	I	Module input channel 3+
E6	DIN3n	I	Module input channel 3-
E7	GND	P	electrical ground
E8	GND	P	electrical ground
E9	GND	P	electrical ground
E10	Vendor Specific		Vendor specific; leave unconnected when not in use; not required for MSA compatibility
F1	GND	P	electrical ground
F2	GND	P	electrical ground
F3	DIN5p	I	Module input channel 5+
F4	DIN5n	I	Module input channel 5-
F5	GND	P	electrical ground
F6	DIN2p	I	Module input channel 2+
F7	DIN2n	I	Module input channel 2-
F8	GND	P	electrical ground
F9	GND	P	electrical ground
F10	Vendor Specific		Vendor specific; leave unconnected when not in use; not required for MSA compatibility
G1	GND	P	electrical ground
G2	GND	P	electrical ground
G3	GND	P	electrical ground
G4	DIN4p	I	Module input channel 4+
G5	DIN4n	I	Module input channel 4-
G6	GND	P	electrical ground
G7	DIN1p	I	Module input channel 1+
G8	DIN1n	I	Module input channel 1-

SNAP12 MSA

TX Pin	Name	Type	Function
G9	GND	P	electrical ground
G10	Vendor Specific		Vendor specific; leave unconnected when not in use; not required for MSA compatibility
H1	NIC		no internal connection within module
H2	NIC		no internal connection within module
H3	VCC	P	Power supply
H4	VCC	P	Power supply
H5	VCC	P	Power supply
H6	VCC	P	Power supply
H7	NIC		no internal connection within module
H8	-FAULT	O	Transmitter fault; HIGH = normal operation; LOW = transmitter in fault condition, see note 2
H9	TXDIS	I	Laser disable; LOW = normal operation if TXEN normal, HIGH = lasers off; internal pull-down, see note 1
H10	Vendor Specific		Vendor specific; leave unconnected when not in use; not required for MSA compatibility
J1	NIC		no internal connection within module
J2	NIC		no internal connection within module
J3	VCC	P	Power supply
J4	VCC	P	Power supply
J5	VCC	P	Power supply
J6	VCC	P	Power supply
J7	NIC		no internal connection within module
J8	-RESET	I	Module reset upon fault; HIGH = normal operation; toggle LOW to clear fault; see note 3
J9	TXEN	I	Laser enable; HIGH = normal operation if TXDIS normal, LOW = lasers off; internal pull-up, see note 1
J10	Vendor Specific		Vendor specific; leave unconnected when not in use; not required for MSA compatibility
K1	NIC		no internal connection within module
K2	NIC		no internal connection within module
K3	NIC		no internal connection within module
K4	NIC		no internal connection within module
K5	NIC		no internal connection within module
K6	NIC		no internal connection within module
K7	NIC		no internal connection within module
K8	NIC		no internal connection within module
K9	NIC		no internal connection within module
K10	NIC		no internal connection within module

Notes:

1. Type Column. I: Input signal. O: Output signal. P: Power or Ground
2. TXEN must be HIGH and TXDIS must be LOW for the transmitter to function. If either is not properly set, the transmitter's lasers will be off.
3. During a fault (FAULT) the lasers are disabled to ensure an eye safe optical output level. To clear a transmitter fault, a RESET signal must be sent to the module.
4. Toggling RESET low will reset the laser circuitry and disable all laser outputs. Fault may be active (LOW) when RESET is active (LOW). During power-up, RESET must remain active (logic low) until the power supply (Vcc) has reached a minimum of 3V

SNAP12 MSA

Table 9 - Receiver Module Pin Functionality

RX Pin	Name	Type	Function
A1	NIC		no internal connection within module
A2	GND	P	electrical ground
A3	GND	P	electrical ground
A4	NIC		no internal connection within module
A5	GND	P	electrical ground
A6	GND	P	electrical ground
A7	NIC		no internal connection within module
A8	NIC		no internal connection within module
A9	NIC		no internal connection within module
A10	Vendor Specific		Vendor specific; leave unconnected when not in use; not required for MSA compatibility
B1	GND	P	electrical ground
B2	DOU9n	O	Module input channel 9-
B3	DOU9p	O	Module input channel 9+
B4	GND	P	electrical ground
B5	DOU10p	O	Module input channel 10+
B6	DOU10n	O	Module input channel 10-
B7	GND	P	electrical ground
B8	GND	P	electrical ground
B9	GND	P	electrical ground
B10	Vendor Specific		Vendor specific; leave unconnected when not in use; not required for MSA compatibility
C1	GND	P	electrical ground
C2	GND	P	electrical ground
C3	DOU8n	O	Module input channel 8-
C4	DOU8p	O	Module input channel 8+
C5	GND		electrical ground
C6	DOU11p	O	Module input channel 11+
C7	DOU11n	O	Module input channel 11-
C8	GND	P	electrical ground
C9	GND	P	electrical ground
C10	Vendor Specific		Vendor specific; leave unconnected when not in use; not required for MSA compatibility
D1	GND	P	electrical ground
D2	GND	P	electrical ground
D3	GND	P	electrical ground
D4	DOU7n	O	Module input channel 7-
D5	DOU7p	O	Module input channel 7+
D6	GND	P	electrical ground
D7	DOU12p	O	Module input channel 12+-
D8	DOU12n	O	Module input channel 12-
D9	GND	P	electrical ground
D10	Vendor Specific		Vendor specific; leave unconnected when not in use; not required for MSA compatibility
E1	GND	P	electrical ground
E2	DOU6n	O	Module input channel 6-

SNAP12 MSA

RX Pin	Name	Type	Function
E3	DOUT6p	O	Module input channel 6+
E4	GND	P	electrical ground
E5	DOUT3n	O	Module input channel 3-
E6	DOUT3p	O	Module input channel 3+
E7	GND	P	electrical ground
E8	GND	P	electrical ground
E9	GND	P	electrical ground
E10	Vendor Specific		Vendor specific; leave unconnected when not in use; not required for MSA compatibility
F1	GND	P	electrical ground
F2	GND	P	electrical ground
F3	DOUT5n	O	Module input channel 5-
F4	DOUT5p	O	Module input channel 5+
F5	GND	P	electrical ground
F6	DOUT2n	O	Module input channel 2-
F7	DOUT2p	O	Module input channel 2+
F8	GND	P	electrical ground
F9	GND	P	electrical ground
F10	Vendor Specific		Vendor specific; leave unconnected when not in use; not required for MSA compatibility
G1	GND	P	electrical ground
G2	GND	P	electrical ground
G3	GND	P	electrical ground
G4	DOUT4n	O	Module input channel 4-
G5	DOUT4p	O	Module input channel 4+
G6	GND	P	electrical ground
G7	DOUT1n	O	Module input channel 1-
G8	DOUT1p	O	Module input channel 1+
G9	GND	P	electrical ground
G10	Vendor Specific		Vendor specific; leave unconnected when not in use; not required for MSA compatibility
H1	NIC		no internal connection within module
H2	NIC		no internal connection within module
H3	VCC	P	Power supply
H4	VCC	P	Power supply
H5	VCC	P	Power supply
H6	VCC	P	Power supply
H7	SD	O	Global signal detect; HIGH = normal operation, LOW = inadequate power on one or more channels
H8	[SD1]	O	Optional: Signal detect channel 1; HIGH = normal operation, LOW = inadequate power on channel 1.
H9	[ENSD]	I	Optional: Signal detect enable; HIGH = normal operation, LOW = signal detect output(s) forced active; internal pull-up
H10	Vendor Specific		Vendor specific; leave unconnected when not in use; not required for MSA compatibility
J1	NIC		no internal connection within module
J2	NIC		no internal connection within module
J3	VCC	P	Power supply
J4	VCC	P	Power supply

SNAP12 MSA

RX Pin	Name	Type	Function
J5	VCC	P	Power supply
J6	VCC	P	Power supply
J7	NIC		no internal connection within module
J8	[-SD12]	I	Optional: Signal detect channel 12; LOW = normal operation, HIGH = inadequate power on channel 12.
J9	[RXEN]	I	Optional: Output enable; HIGH = normal operation, LOW = receiver disabled; internal pull-up
J10	Vendor Specific		Vendor specific; leave unconnected when not in use; not required for MSA compatibility
K1	VPP	P	Power supply, connect to VCC for AC-coupling, see Table 6 for DC coupling
K2	VPP	P	Power supply, connect to VCC for AC-coupling, see Table 6 for DC couplings
K3	NIC		no internal connection within module
K4	NIC		no internal connection within module
K5	NIC		no internal connection within module
K6	NIC		no internal connection within module
K7	NIC		no internal connection within module
K8	VPP	P	Power supply, connect to VCC for AC-coupling, see Table 6 for DC coupling
K9	VPP	P	Power supply, connect to VCC for AC-coupling, see Table 6 for DC coupling
K10	[SQEN]	I	Optional: Squelch enable; HIGH = all data outputs driven to logic zero when SD is active (LOW), LOW = squelch disabled; internal pull-up

Figure 7 - Transmitter Pin Layout

(Toward MPO connector end of module)

	K	J	H	G	F	E	D	C	B	A
1	NIC	NIC	NIC	GND	GND	GND	GND	GND	GND	NIC
2	NIC	NIC	NIC	GND	GND	DIN6p	GND	GND	DIN9p	GND
3	NIC	VCC	VCC	GND	DIN5p	DIN6n	GND	DIN8p	DIN9n	GND
4	NIC	VCC	VCC	DIN4p	DIN5n	GND	DIN7p	DIN8n	GND	NIC
5	NIC	VCC	VCC	DIN4n	GND	DIN3p	DIN7n	GND	DIN10n	GND
6	NIC	VCC	VCC	GND	DIN2p	DIN3n	GND	DIN11n	DIN10p	GND
7	NIC	NIC	NIC	DIN1p	DIN2n	GND	DIN12n	DIN11p	GND	NIC
8	NIC	-RESET	-FAULT	DIN1n	GND	GND	DIN12p	GND	GND	NIC
9	NIC	TXEN	TXDIS	GND	GND	GND	GND	GND	GND	NIC
10	NIC	Vendor Specific	Vendor Specific	Vendor Specific	Vendor Specific	Vendor Specific	Vendor Specific	Vendor Specific	Vendor Specific	Vendor Specific

(Top view as looking down onto the host PWB)

Figure 8 - Receiver Pin Layout

(Toward MPO connector end of module)

	K	J	H	G	F	E	D	C	B	A
1	VPP	NIC	NIC	GND	GND	GND	GND	GND	GND	NIC
2	VPP	NIC	NIC	GND	GND	DOUT6n	GND	GND	DOUT9n	GND
3	NIC	VCC	VCC	GND	DOUT5n	DOUT6p	GND	DOUT8n	DOUT9p	GND
4	NIC	VCC	VCC	DOUT4n	DOUT5p	GND	DOUT7n	DOUT8p	GND	NIC
5	NIC	VCC	VCC	DOUT4p	GND	DOUT3n	DOUT7p	GND	DOUT10p	GND
6	NIC	VCC	VCC	GND	DOUT2n	DOUT3p	GND	DOUT11p	DOUT10n	GND
7	NIC	NIC	SD	DOUT1n	DOUT2p	GND	DOUT12p	DOUT11n	GND	NIC
8	VPP	[-SD12]	[SD1]	DOUT1p	GND	GND	DOUT12n	GND	GND	NIC
9	VPP	[RXEN]	[ENSD]	GND	GND	GND	GND	GND	GND	NIC
10	[SQEN]	Vendor Specific	Vendor Specific	Vendor Specific	Vendor Specific	Vendor Specific	Vendor Specific	Vendor Specific	Vendor Specific	Vendor Specific

(Top view as looking down onto the host PWB)

9. Control and Status Timing Diagrams

The following figures and subsequent table show and tabulate the timing relationships of the status and control signals of the pluggable parallel optical modules. As specified in the previous section, some of these signals are optional.

Figure 9 - Transmitter Fault

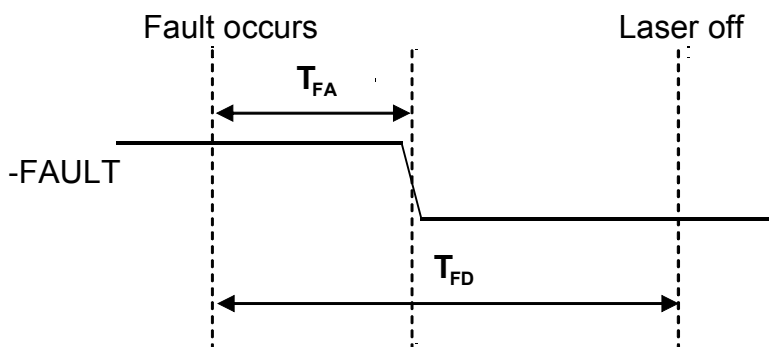

Figure 10 - Transmitter Initialization and Fault Reset Timing

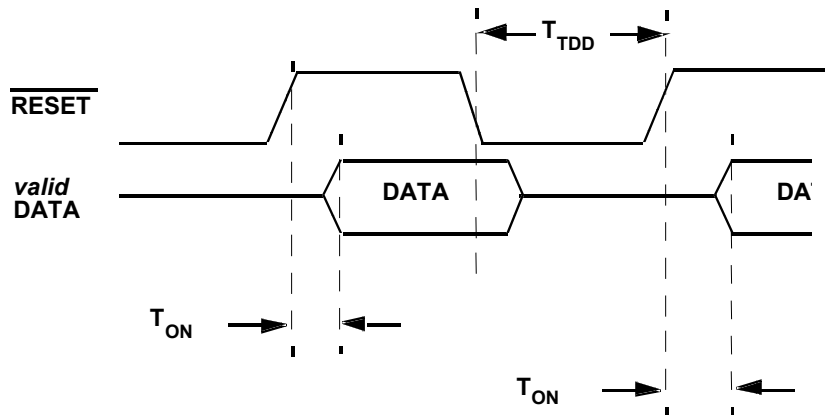

Figure 11 - Transmitter Enable / Disable Timing

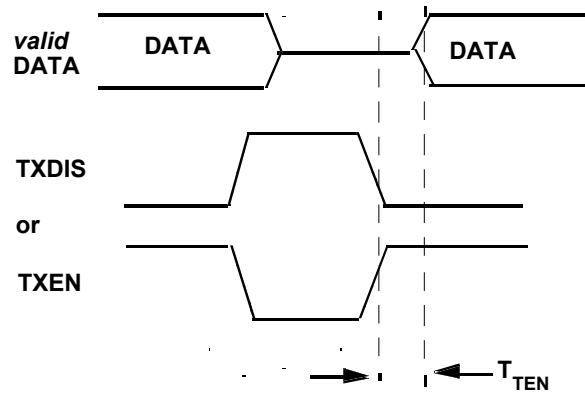

Figure 12 - Receiver Signal Detect Timing

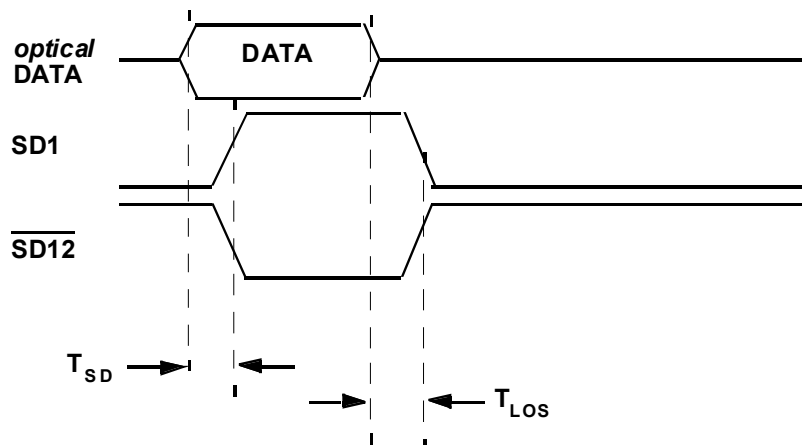

Figure 13 - Receiver Enable Timing

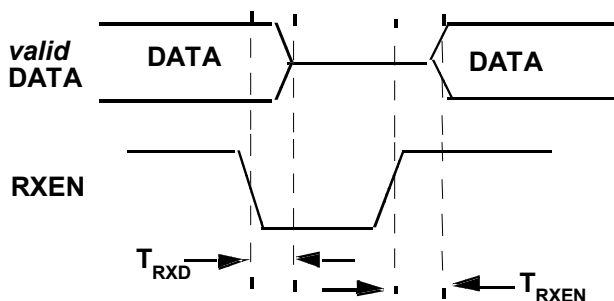

Table 10 - Timing Requirements of Control and Status Signals

Parameter	Symbol	Min	Typ	Max	Unit	Comment
-FAULT assert time	T_{FA}			100	μs	Time from occurrence of a transmitter fault to the -FAULT signal going active (LOW)
-FAULT lasers off	T_{FD}			100	μs	Time from occurrence of a transmitter fault to the lasers shutting off
-RESET duration	T_{TDD}	10			μs	Minimum hold time for -RESET active (LOW) to clear a fault
-RESET de-assert time	T_{ON}		33	100	ms	Time until data is valid after RESET de-assert (HIGH)
TXEN assert time	T_{TEN}			1	ms	Time until data is valid after TXEN active (HIGH)
TXDIS de-assert time	T_{TEN}			1	ms	Time until data is valid after TXDIS de-assert (HIGH)
SD assert time (also SD1 assert and -SD12 de-assert)	T_{SD}		50		μs	Time after valid data until SD is active (HIGH)
SD de-assert time (also SD1 de-assert and -SD12 assert)	T_{LOS}		50		μs	Time after data no longer valid until SD is de-active (LOW)
RXEN assert time	T_{RXEN}		33		ms	Time until data is valid after RXEN active (HIGH)
RXEN de-assert time	T_{RXD}		5		μs	Time after RXEN de-active (LOW) during which data is still valid

Optical Interface

Each module shall have twelve optical channels.

10. Transmitter Optical Specifications

Table 11 - Transmitter Optical Specifications

Parameter (per channel)	Min	Max	Unit	Note
Modulation data rate		2.72	Gbps	
Average optical output power (per channel) – enabled	-8	-2	dBm	1
Average optical output power (per channel) – disabled		-30	dBm	
Extinction Ratio	3		dB	
Optical Modulation Amplitude (OMA)	-7.21 (190)		dBm (μ W)	2
Center Wavelength	830	860	nm	
Spectral width (RMS)		0.85	nm	
Optical rise/fall time (20-80%)		160	ps	
Relative intensity noise (RIN ₁₂ OMA)		-116	dB/Hz	
Deterministic jitter		0.14	UI	
Total jitter		0.33	UI	
Inter-channel optical skew introduced by the transmitter for simultaneous electrical inputs		200	ps	

For case temperatures from 0 to 80°C and across the specified supply voltage range.

Notes.

- The transmitter shall conform to the requirements for Class 1M classification for the IEC 60825 Amendment 2 and Class 1 classification for the FDA CDRH 21 CFR 1040 accounting for Laser Notice 50.
- Optical Modulation Amplitude (OMA) of 190 μ W (-7.21 dBm) peak-peak is equivalent to 6 dB ER at -8.0 dBm.
- The transmitter filtered eye (4th order Bessel-Thomson) shall also pass the P802.3ae 10GBASE-S eye mask.

11. Receiver Optical Specifications

Table 12 - Receiver Optical Specifications

Parameter (per channel)	Min	Max	Unit	Notes
Modulation data rate		2.72	Gbps	
Average optical input power (sensitivity / saturation)	-16	-2	dBm	1
Stressed sensitivity		-12	dBm	2
Stressed eye opening (electrical output eye opening)	120		ps	2
Center wavelength	830	860	nm	
Return Loss	12		dB	
Deterministic jitter		0.14	UI	
Total jitter		0.39	UI	
Electrical rise/fall time (20-80%)		150	ps	
Signal detect assert level		-17	dBm	
Signal detect de-assert level	-30		dBm	
Signal detect hysteresis	1		dB	
Inter-channel electrical skew introduced by the receiver for simultaneous optical inputs		200	ps	

For case temperatures from 0 to 80°C and across the specified supply voltage range.

Notes:

1. Sensitivity and saturation parameters measured using a Pseudo Random Bit Sequence (PRBS) $2^{23} - 1$, an extinction ratio (ER) greater than 6 dB and a maximum bit error rate (BER) of 10^{-12} . For sensitivity measurements, the maximum BER shall be maintained in the presence of the maximum crosstalk penalty. The maximum crosstalk possibility is defined as the 'victim' receiver channel operating at its sensitivity limit and remaining eleven the 'aggressor' receiver channels being actively driven at 6 dB higher incident power and 2.72 Gbps data rate. The minimum average optical power and minimum extinction ratio is equivalent to 30 μ W Optical Modulation Amplitude (OMA).
2. Stressed sensitivity and stressed eye opening parameters are informative parameters. Stressed sensitivity and stressed eye opening parameters measured using a Pseudo Random Bit Sequence (PRBS) $2^{23} - 1$, an Intersymbol Interference (ISI) closure of 2 dB and a maximum bit error rate (BER) of 10^{-12} . These parameters are based on the parameters of the same name in IEEE 802.3z 1000Base-SX.

12. Optical Signal Locations

Table 13 - Transmitter Optical Signal Locations

Viewed Looking into Front of Optical Connector Receptacle
(Top of Module)

FOUT12	FOUT11	FOUT10	FOUT09	FOUT08	FOUT07	FOUT06	FOUT05	FOUT04	FOUT03	FOUT02	FOUT01
--------	--------	--------	--------	--------	--------	--------	--------	--------	--------	--------	--------

(Bottom of Module – Toward Host Circuit Card)

Table 14 - Receiver Optical Signal Locations

Viewed Looking into Front of Optical Connector Receptacle
(Top of Module)

FIN12	FIN11	FIN10	FIN09	FIN08	FIN07	FIN06	FIN05	FIN04	FIN03	FIN02	FIN01
-------	-------	-------	-------	-------	-------	-------	-------	-------	-------	-------	-------

(Bottom of Module – Toward Host Circuit Card)

13. Cable Plant Specifications

The following table lists the minimum reach distance of the parallel optical modules for different multi-mode fiber (MMF) types and bandwidths for a data signal modulated at the maximum data rate of 2.7 Gbps. Each case includes a maximum of 2 dB per channel connection loss for path cables and other connectors.

Table 15 - Cable Plant Specifications

Fiber Type (core / cladding μ m)	Modal Bandwidth at 850nm (MHz•km)	Reach Distance (m)
62.5 / 125 MMF	200	150
62.5 / 125 or 50 / 125 MMF	400	260
50 / 125 MMF	500	300
50 / 125 MMF	2000	600

Electrical Interface – Application Examples

14. Application Examples

This section includes diagrams that show possible implementation examples of the high-speed electrical interface for AC and DC-coupling between the pluggable parallel optical modules and host circuitry. All components within the dashed line around the module are contained within the module. Any component outside the dashed line around the module must be supplied on the host printed circuit board.

Figure 14 - AC-Coupling into Tx Optical Module

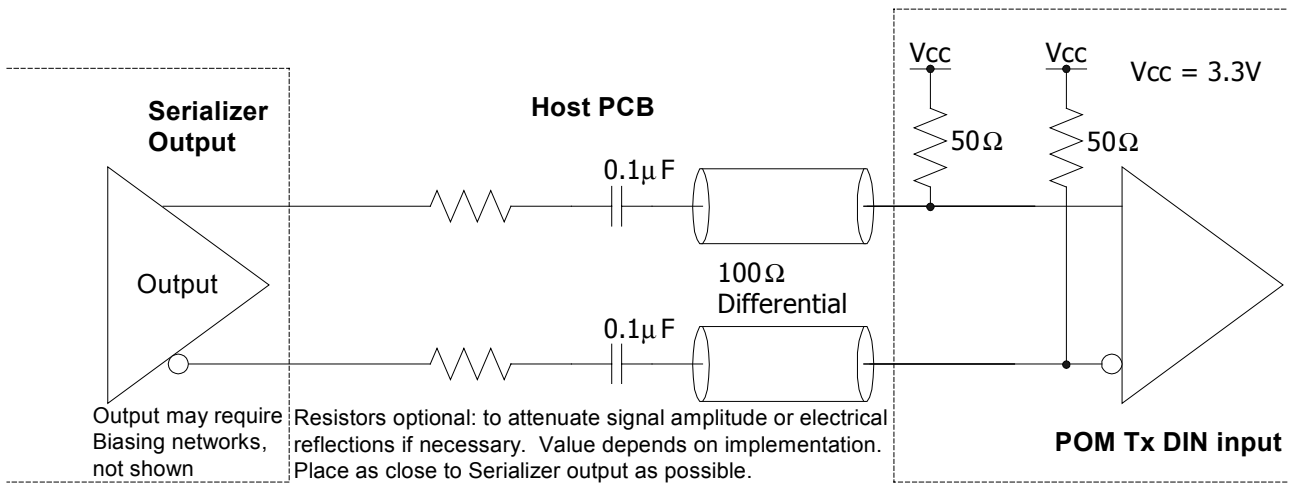

Figure 15 - DC-Coupling into Tx Optical Module

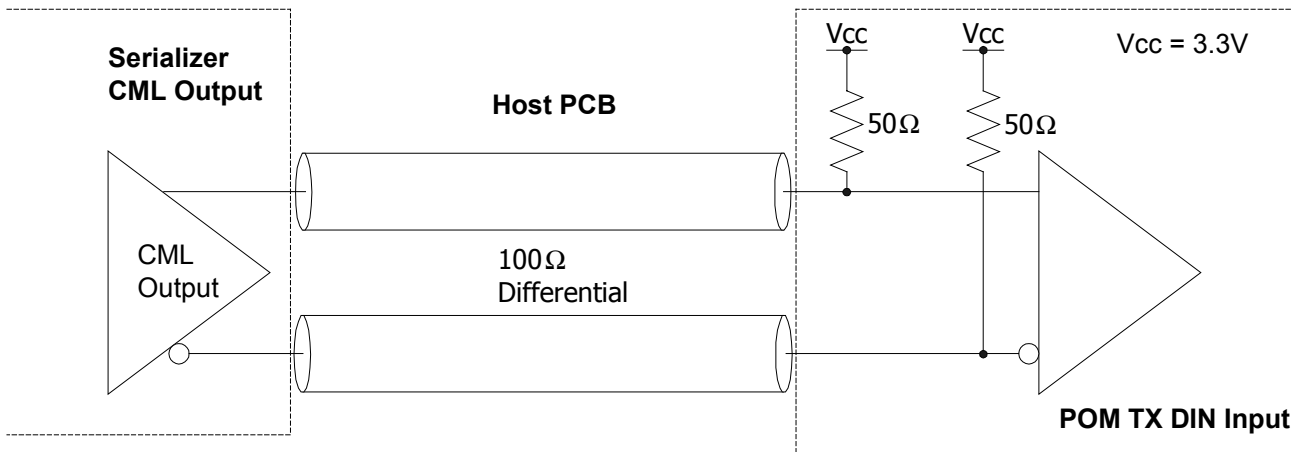

Figure 16 - AC-Coupling from Rx Optical Module

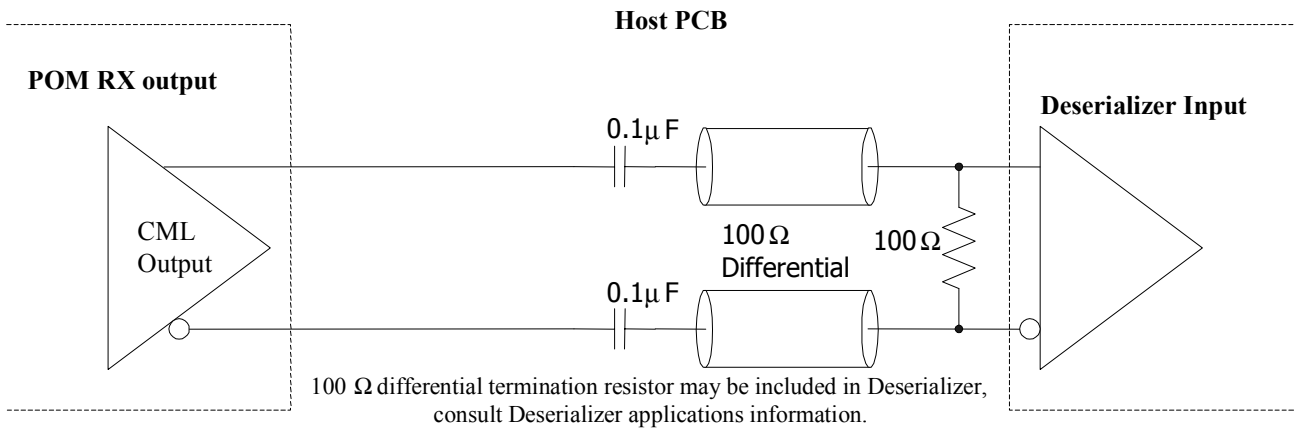

Figure 17 - DC-Coupling from Rx Optical Module

